

BV600

Air Filtration Unit

**BenchVent**  
The Bench Ventilation Company

## Portable Tanning Mist Filtration Cabinets

Vastly reduce overspray and particle deposits

For a cleaner, healthier working environment for the small salon user and mobile therapist.

---



Demonstrating adequate control of the risks to the health of employees, students and the general public, from dusts, powders, mists, fumes and vapours is the fundamental requirement of the Control of Substances Hazardous to Health (COSHH) regulations 2002 and 2004.

[www.benchvent.com](http://www.benchvent.com)

# BenchVent Spray Tan Filtration Cabinets

NOTE: These units are recirculatory; i.e. filtered air is exhausted back into the workplace.

For a cleaner, healthier working environment.

## Description

Steel construction, finished in black powder coating – back stand – carry Handle – particulate and moisture filters – 2 x rotor motor axial fans, brushless, UL, VDE and CSA approved - sealed electrical wiring and switch, downstream of filters

## Operation

All WS filtration and extraction systems carry a lifetime warranty, are quiet in operation and can be assembled in seconds. Place onto a desk, bench or trolley and then simply plug in and switch on. These tanning units are floor standing and can be used with a spray tan cubicle/tent for maximum effect. Ideal for stand alone use in small tanning room.

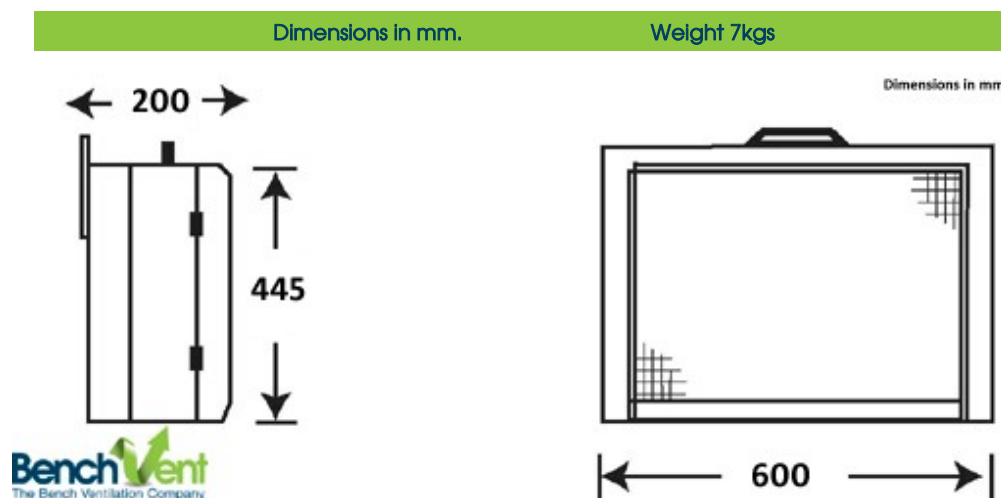

## Filtration

The particulate (intake) filter is a three stage graduated fibre filter with a high 'dust' holding capacity for long life. Filtration to 5 micron particles. NB: Spray particulate sizes vary from 10 to 20 microns.

The dual process of filtration and then extraction to atmosphere via flexi-duct, vastly reduces and/or eliminates operator exposures to potentially hazardous substances.

## Specification

Model Number	Fan Motor* Spec	Air Volume At Free Air	Ave. Air Velocity At Filter Face	Noise Level LAeq dB(A)
BV600	230V 50Hz 80W	650m <sup>3</sup> /hr	0.6m/sec	50

\*110v 50 or 60Hz available on request

These units are designed as mobile 'spray traps' to assist with cleanliness and for immediate operator and client protection from concentrations of airborne tanning solution mist. They are not recommended for continual usage in confined and/or badly ventilated areas. See Salon Spray Booths BV1000 and BV2000 for higher specification filtration and extraction

Please contact BenchVent for advice on the choice of machine for any given situation.

T: 01423 790039

E: [enquiries@benchvent.com](mailto:enquiries@benchvent.com)

W: [www.benchvent.com](http://www.benchvent.com)

BenchVent, Unit 1 Levens Hall Park, Lund Lane, Killinghall, Harrogate, North Yorkshire. HG3 2BG

Company No: 03217859 Registered office: Widespread Solutions Ltd, Unit 1 Levens Hall Park, Lund Lane, Killinghall, Harrogate, North Yorkshire. HG3 2BG

BenchVent is a trading style of Widespread Solutions Ltd

We go to great lengths to ensure accuracy in our literature, however we cannot be held responsible for errors or omissions. Information is given for guidance only and we reserve the right to alter specification.