

BV500S-C

Air Filtration Cabinets



Desk/Bench top fume cabinets

Contain and filter for a cleaner, healthier working environment within dental labs, electronic design and rework, pharmaceutical labs, design and technology, science in education and more..... For use in numerous situations where external venting is impractical but where contaminant capture and filtration is necessary.

Applications include the filtration of fumes, vapour and particulates emanating from:

Monomers, adhesives, hazardous powders/particulates, conformal coatings, resins, sealants, solders, light grinding particles and dusts, organic solvents etc.

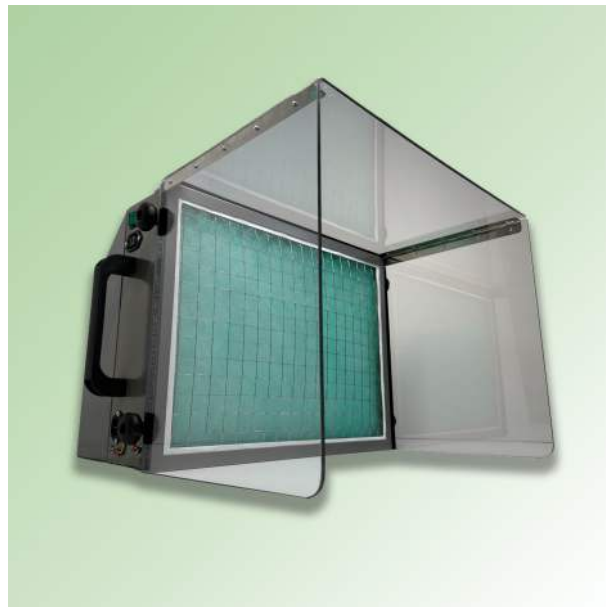

Demonstrating adequate control of the risks to the health of employees, students and the general public, from dusts, powders, mists, fumes and vapours is the fundamental requirement of the Control of Substances Hazardous to Health (COSHH) regulations 2002 and 2004.

www.benchvent.com

BenchVent Air Filtration Unit

NOTE: These units are recirculatory; i.e. filtered air is exhausted back into the workplace.

For a cleaner, healthier working environment.

Description

Fan/filter casing (steel construction finished in grey) – clear Polycarbonate folding plastic fume shield – particulate (Intake Filter) – bonded carbon filter – centrifugal blower, external rotor motor type brushless, UL, VDE and CSA approved - sealed electrical wiring and switch, downstream of filters.

Operation

All BV filtration and extraction systems carry a lifetime warranty, are quiet in operation and can be assembled in seconds. Place onto a desk, bench or trolley and then simply plug in and switch on.

The folding Polycarbonate shield can be stored if not required thus reducing the unit footprint considerably. Handling and / or use of potentially harmful substances is carried out in front of the intake filter area. Cleaned air is vented to the top rear of the units.

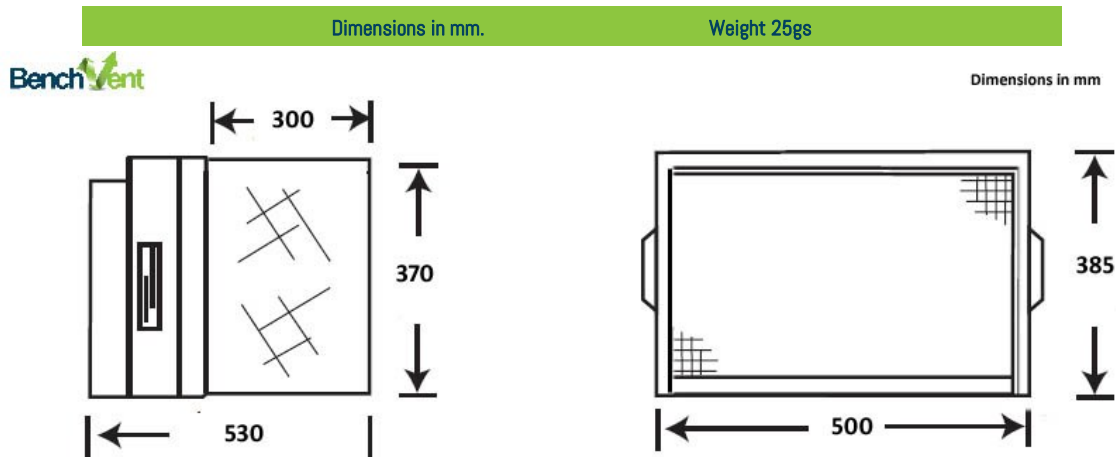

Filtration

The particulate (intake) filter is a three stage graduated fibre filter (filtration to 5.0 micron particles) with a high 'dust' holding capacity for long life. (Optional EPA filters available to approx 0.3micron particles). This is followed by a high grade bonded carbon filter.

Specification

Model Number	Fan Motor* Spec	Air Volume At Free Air	Ave. Air Velocity At Filter Face	Ave. Air velocity At Shield Face	Noise Level LAeq dB (A)
BV500S-C	230V 50Hz 105W	355m ³ /hr	0.55m/sec	0.38m/sec	60

*115v 60Hz available on request

These units are designed for immediate operator protection from concentrations of airborne contaminants whereby all gases, fumes, vapours and particulates at the front of the unit are drawn into the intake filter. Cleaned air is exhausted to the top rear of the cabinet.

See BV660's and BV930'S Fume Hoods and Cabinets for higher specification requirements

Please contact BenchVent for advice on the choice of machine for any given situation.

T: 01423 790039

E: enquiries@benchvent.com

W: www.benchvent.com

BenchVent, Unit 1 Levens Hall Park, Lund Lane, Killinghall, Harrogate, North Yorkshire. HG3 2BG

Company No: 03217859 Registered office: Widespread Solutions Ltd, Unit 1 Levens Hall Park, Lund Lane, Killinghall, Harrogate, North Yorkshire. HG3 2BG

BenchVent is a trading style of Widespread Solutions Ltd

We go to great lengths to ensure accuracy in our literature, however we cannot be held responsible for errors or omissions. Information is given for guidance only and we reserve the right to alter specification.