

BV660H-C

Air Filtration Cabinets

Fume Filtration Hoods and Cabinets

Capture, contain and filter for a cleaner, healthier working environment within electronic design and rework, dental/medical labs, pharmaceutical labs, design and technology, science in education and more..... For use in a multitude of situations where external venting is impractical but where contaminant capture and filtration is necessary.

Applications include the filtration of fumes, vapour and particulates emanating from:

Spray adhesives, conformal coatings and paints, monomers, hazardous powders and particulates, resins, sealants, solders, light grinding particles, organic solvents and cleaners etc.

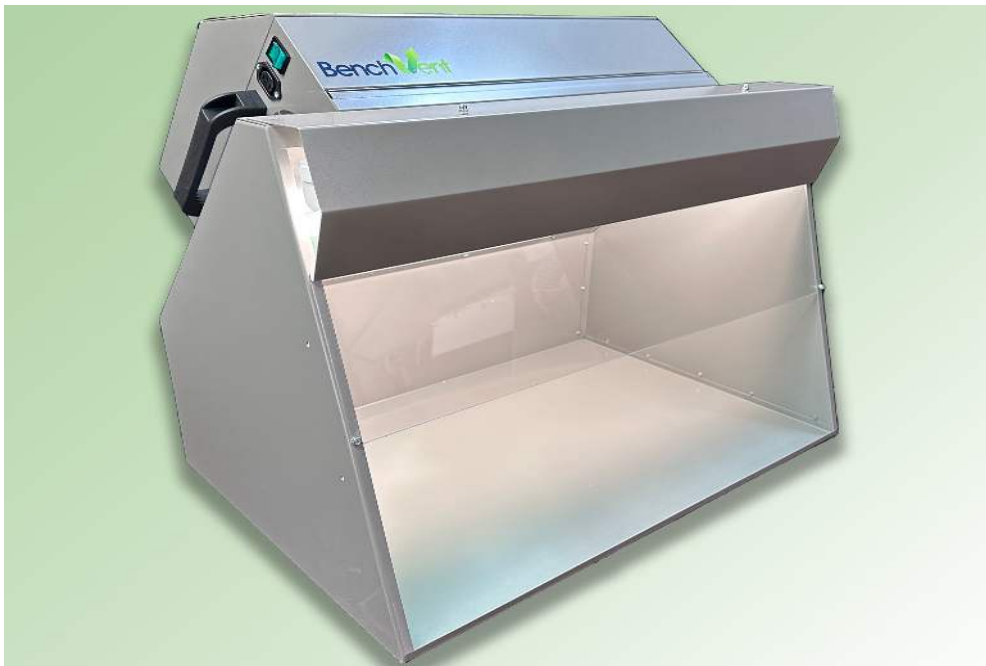

Demonstrating adequate control of the risks to the health of employees, students and the general public, from dusts, powders, mists, fumes and vapours is the fundamental requirement of the Control of Substances Hazardous to Health (COSHH) regulations 2002 and 2004.

BenchVent Air Filtration Unit

NOTE: These units are recirculatory; i.e. filtered air is exhausted back into the workplace

For a cleaner, healthier working environment.

Description

Steel construction finished in dove grey – fan/filter unit mounted onto hood enclosure complete with clear polycarbonate panel and hood lighting – particulate (intake) filter – bonded carbon filter – centrifugal blower, external rotor motor type brushless, UL, VDE and CSA approved - sealed electrics, downstream of filters.

Operation

All BV filtration and extraction systems carry a lifetime warranty, are quiet in operation and can be assembled in seconds. Place onto a desk, bench or trolley and then simply plug in and switch on.

Handling and / or use of potentially harmful substances is carried out within the hood enclosure in front of the intake filter area. Cleaned air is vented to the top rear of the units. For artwork applications, standard A2 drawing boards can be placed within the hood enclosure. The boards fit at an angle for efficient overspray capture. Optional UV light can be fitted for PCB inspection.

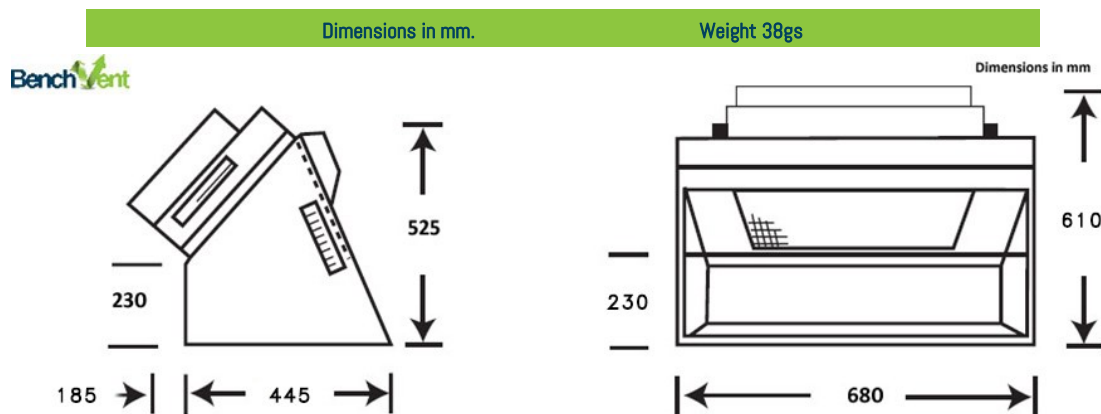

Filtration

The particulate (intake) filter is a three stage graduated fibre filter with a high 'dust' holding capacity for long life. Filtration to 5 micron particles. (Optional EPA filters available to approx 0.3micron particles). This is followed by a high grade bonded carbon filter.

Through the process of filtration, adsorption and dilution, operator exposure to potentially hazardous substances is vastly reduced or eliminated.

Specification

Model Number	Fan Motor* Spec	Air Volume At Free Air	Ave. Air Velocity At Filter Face	Ave. Air velocity At Shield Face	Noise Level LAeq dB(A)
BV660H-C	230V 50Hz 105W	355m ³ /hr	0.50m/sec	0.50m/sec	60

These units are designed for immediate operator protection from concentrations of airborne contaminants whereby all gases, fumes, vapours and particulates within the hood enclosure are filtered and cleaned air is exhausted to the top rear of the cabinet. See BenchVent extraction cabinets No's BV660H-D and BV930H-D should total fume and/or /gas extraction be required

Please contact BenchVent for advice on the choice of machine for any given situation.

T: 01423 790039

E: enquiries@benchvent.com

W: www.benchvent.com

BenchVent, Unit 1 Levens Hall Park, Lund Lane, Killinghall, Harrogate, North Yorkshire. HG3 2BG

Company No: 03217859 Registered office: Widespread Solutions Ltd, Unit 1 Levens Hall Park, Lund Lane, Killinghall, Harrogate, North Yorkshire. HG3 2BG

BenchVent is a trading style of Widespread Solutions Ltd

We go to great lengths to ensure accuracy in our literature, however we cannot be held responsible for errors or omissions. Information is given for guidance only and we reserve the right to alter specification.