



## Operating & Maintenance Manual

### Circulaire® **Downflow Workstation**

W700/W1000

Create a cleaner & healthier work environment

[www.benchvent.com](http://www.benchvent.com)

This manual is intended to provide information about the product.  
BENCHVENT assumes no liability whatsoever for the accuracy of any information contained herein, as products can be subject to improvement changes at any time.

The contents may not be distributed, shared or commercially exploited in any form or by any means, redistributed or reproduced in entirety or in part in any form, for individual or third party use, photocopied or stored on any form of electronic retrieval system or linked to any other website, without the prior express written permission of BENCHVENT.

For permission requests, please write to:-  
SALES@BENCHVENT.COM

# CONTENTS

<b>SECTION 1</b> .....	<b>4</b>
DESCRIPTION OF THE CABINET .....	4
<b>SECTION 2</b> .....	<b>5</b>
INSTALLATION.....	5
ASSEMBLY.....	5
REMOVAL OF HEAD SECTION .....	5
TESTING / COMMISSIONING.....	5
<b>SECTION 3</b> .....	<b>6</b>
OPERATION.....	6
<b>SECTION 4</b> .....	<b>7</b>
FILTERS.....	7
FILTER SELECTION.....	7
MAXIMISING FILTER LIFE .....	8
CARBON FILTER EFFICIENCIES .....	8
ABSORBTION CAPACITIES .....	8
<b>SECTION 5</b> .....	<b>9</b>
MAINTENANCE .....	9
FUSES .....	9
LIGHTING .....	9
MAIN CARBON FILTERS - CHANGING.....	9
PRE-FILTERS - CHANGING.....	9
MAIN CARBON FILTERS - CHANGING.....	9
ELECTRICAL DIAGRAMS.....	10/11
CALIBRATION - LOW AIRFLOW ALARM .....	12
<b>SECTION 6</b> .....	<b>13</b>
SERVICING .....	13

## Warning

This system must be used in compliance with these instructions and any repairs or maintenance carried out by qualified personnel.

For parts or service information please contact Benchvent on:  
+44 (0) 1423 790039

# SECTION 1

## DESCRIPTION OF THE CABINET

The Circulaire W700 and W1000 Downflow Workstations are designed to provide operator and environmental protection. The cabinets provide a downflow of air  $>0.3\text{m/sec}$  through the perforated worksurface to provide operator protection. The contaminated air is then passed through an electrostatically charged pre-filter to remove particulate and then through an Activated Carbon main filter to remove chemical fumes before exhausting the air back to the laboratory.

	<i>Circulaire W700</i>	<i>Circulaire W1000</i>
External Dimensions	700mmWide 600mmDeep 820mm High	1000mmWide 600mmDeep 820mm High
Internal Dimensions	680mmWide 540mmDeep 400mm High	980mmWide 540mmDeep 400mm High

## **SECTION 2**

### **INSTALLATION**

- The cabinet should be sited in a draught free position
- The cabinet is recirculating and requires no connection to ductwork

### **ASSEMBLY**

The cabinet will normally be delivered fully assembled with the main carbon filter fitted. If required, the head section may be removed to gain access to the main carbon filter or to ease transportation to point of use.

### **REMOVAL OF HEAD SECTION**

1. Disconnect the cabinet from the electrical supply and unplug the power lead.
2. Hinge down the pre-filter retaining frame by releasing the two plunger latches adjacent to the fluorescent light inside the lower enclosure.
3. Slide the white plastic grille towards the back of the cabinet until it drops down and can be withdrawn with the pre-filter.
4. Turn the four black knobs inside the top of the enclosure anticlockwise a quarter of a turn to release the head section.
5. The head section may now be lifted off to gain access to the main carbon filter.

### **TESTING / COMMISSIONING**

A test certificate will be supplied for conformity to CE marking, and electrical test. The airflow should be checked using a vane anemometer and the results recorded.

**THE CABINET MUST BE TESTED EVERY 14 MONTHS TO COMPLY WITH C.O.S.H.H REGULATIONS.**

## SECTION 3

### OPERATION

To turn the cabinet on, press the illuminated rocker switch on the control panel. During start up the low airflow alarm light will flash until the cabinet reaches correct operating speed.

The fluorescent light may be turned on or off by the rocker switch on the control panel.

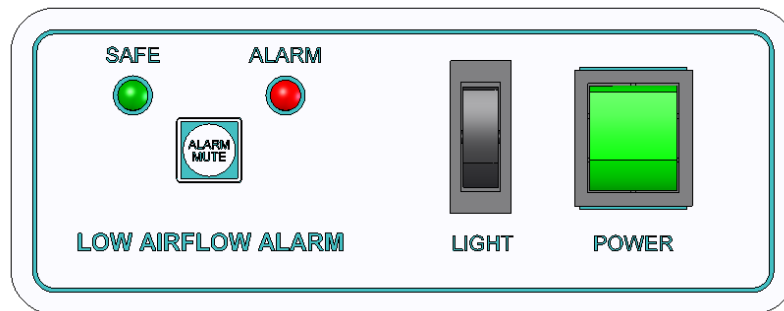

**NOTE:** site safety officer should approve operating procedures prior to starting work.

## SECTION 4

### FILTER SELECTION

It is most important that filters fitted are correct for the particular application. A guide to filter selection is as follows:

Gaseous fumes – Activated Carbon filters. Different grades are available to improve efficiency and extend filter life.

Particulates – HEPA filters. Circulaire HEPA filters are 99.997% efficient for particulates greater than 0.3 microns. For maximum protection against particulates the safety exhaust HEPA filter should be selected. The exhaust filter has seals under negative pressure to eliminate possible filter bypass. The main filter can either be HEPA or activated carbon.

#### Activated Carbon Filters

Standard activated carbon is suitable for a wide range of pollutants including hydrocarbons. Activated carbon can be impregnated with chemicals to neutralise types of chemicals and there is a list on the following page to indicate the types available.

The given weight is approximate to standard activated carbon. Impregnated carbons have higher densities and will increase filter weight.

Filter Type	Application	Typical Chemicals
HEPA	Particulates	Powders
ACTIVATED CARBON – A/C	Hydrocarbons	Alcohols, Hydrocarbons, General use
ACID	Acid gasses	SO <sub>2</sub> , HCL, H <sub>2</sub> SO <sub>4</sub>
FORM	Aldehydes	Formalin Glutaraldehyde
SUL	Sulphur compounds	H <sub>2</sub> S, mercaptans
AMM	Ammonia	NH <sub>3</sub> , NH <sub>4</sub>
ETHER	Ethers	
SCHOOLS	Educational, Animal odours	SO <sub>2</sub> , H <sub>2</sub> SO <sub>4</sub> , BR <sub>2</sub> , H <sub>2</sub> S, NH <sub>3</sub> , CCL <sub>4</sub> , hydrocarbons

- All grades of activated carbon have general use capability for hydrocarbons etc.
- Other grades are available for applications not listed above.
- Filters can be manufactured in layers suitable for more than one application.

To determine correct filter type please contact Benchvent with details of application, volumes, concentrations, temperatures etc.

### **MAXIMISING FILTER LIFE**

Handle minimum volumes of chemicals

Minimise surface area of exposed chemicals to reduce evaporation rates

Cover containers as far as practical

### **CARBON FILTER EFFICIENCIES**

Typical filter efficiencies are >99% and this efficiency is maintained for most of the filter life. Filters should be changed when efficiency has reduced to below 90%.

### **ABSORPTION CAPACITIES**

Circulaire cabinets have very large filter capacities, with a typical value of >30% for hydrocarbons. The W700 & W1000 have the following nominal capacities:

<b>Model</b>	<b>Carbon Weight</b>	<b>Hydrocarbon capacity at 30% absorption</b>
Circulaire W700	1 X 14Kg	4.2Kg
Circulaire W1000	2 X 10.5Kg	6.3Kg

Impregnated filters have different densities and filter capacities. Contact Benchvent for absorption capacities for different applications.



## SECTION 5

### MAINTENANCE

The cabinet should be isolated from the electricity supply before carrying out any maintenance procedures.

#### FUSES

The main fuses are located in the mains inlet socket on the back of the cabinet. Remove the mains lead and withdraw the fuses using a small screwdriver. **Always replace fuses with the correct type and rating.**

#### LIGHTING

The fluorescent light is fitted to the inside of the head section and can be accessed by removing the head as follows:

1. Hinge down the pre-filter retaining frame by releasing the two plunger latches adjacent to the fluorescent light inside the lower enclosure.
2. Slide the white plastic grille towards the back of the cabinet until it drops down and can be withdrawn with the pre-filter.
3. Turn the four black knobs inside the top of the enclosure anticlockwise a quarter of a turn to release the head section.
4. The head section may now be lifted off to gain access to the fluorescent light fitting. The starter is located inside the fitting.

#### PRE-FILTERS - CHANGING

**IMPORTANT:** Personal Protective Equipment must be worn when changing filters.

1. Hinge down the pre-filter retaining frame by releasing the two plunger latches adjacent to the fluorescent light inside the lower enclosure.
2. Slide the white plastic grille towards the back of the cabinet until it drops down and can be withdrawn with the pre-filter.

#### MAIN CARBON FILTERS - CHANGING

**IMPORTANT:** Personal Protective Equipment must be worn when changing filters.

1. Hinge down the pre-filter retaining frame by releasing the two plunger latches adjacent to the fluorescent light inside the lower enclosure.
2. Slide the white plastic grille towards the back of the cabinet until it drops down and can be withdrawn with the pre-filter.
3. Turn the four black knobs inside the top of the enclosure anticlockwise a quarter of a turn to release the head section.
4. The head may now be lifted off to gain access to the main carbon filter.

# ELECTRICAL DIAGRAMS

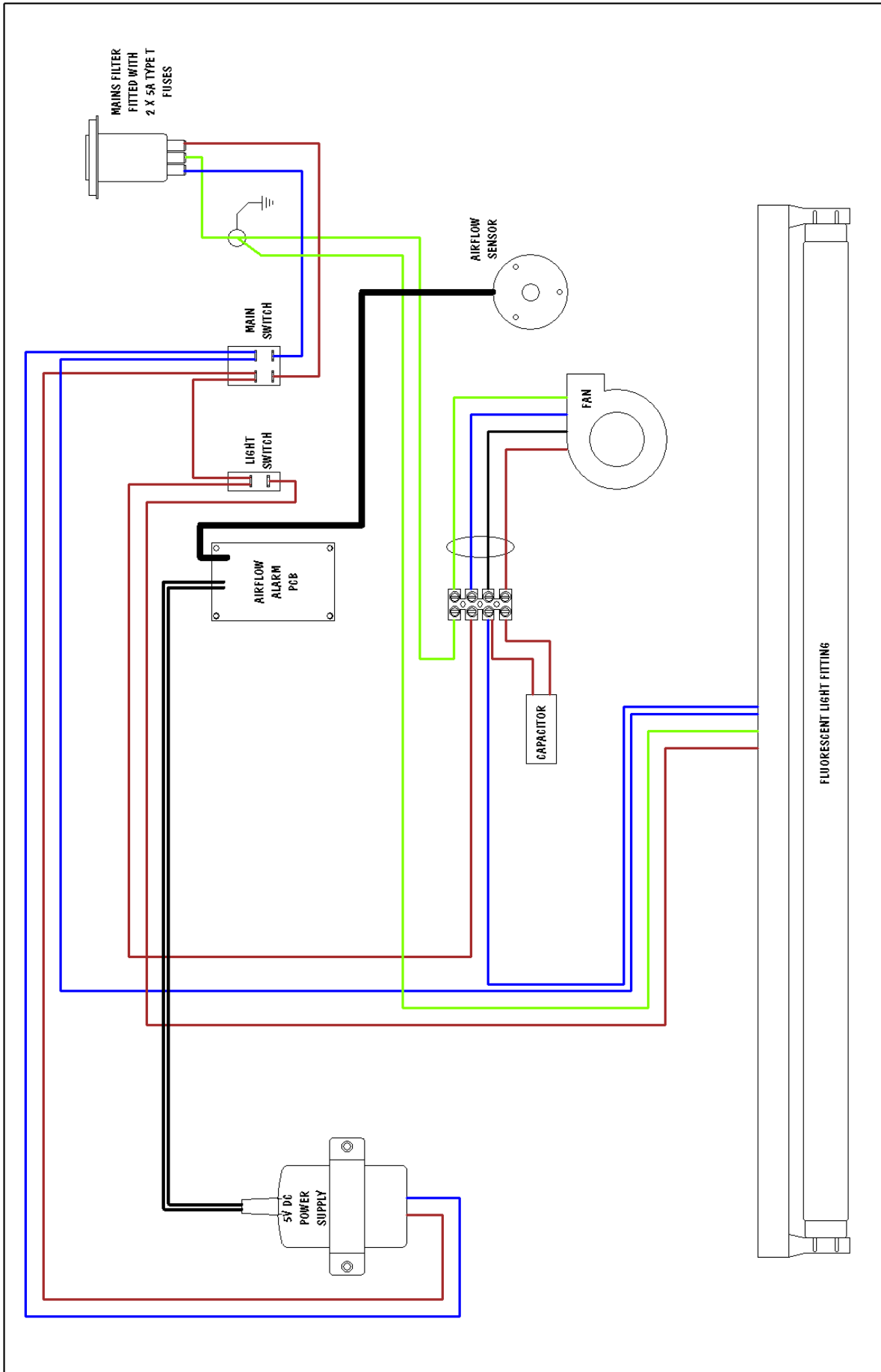

DRAWN PW DATE 12/01/11 PRIVATE AND CONFIDENTIAL	DESCRIPTION		ELECTRICAL DIAGRAM W700
	DRAWING No	DFW / ELEC / 001 SH. 1 OF 1	ISSUE C
<p><b>Monmouth Scientific</b>          A division of Monmouth Surgical Ltd.          Units 5 &amp; 6, Vennish, Briar Quay, Brighthelm          Bournemouth, Dorset, BH2 4JG, England          Tel: +44 (0) 1202 452400          Fax: +44 (0) 1202 452031          email: eng@wiring@monmouthscientific.co.uk</p>			

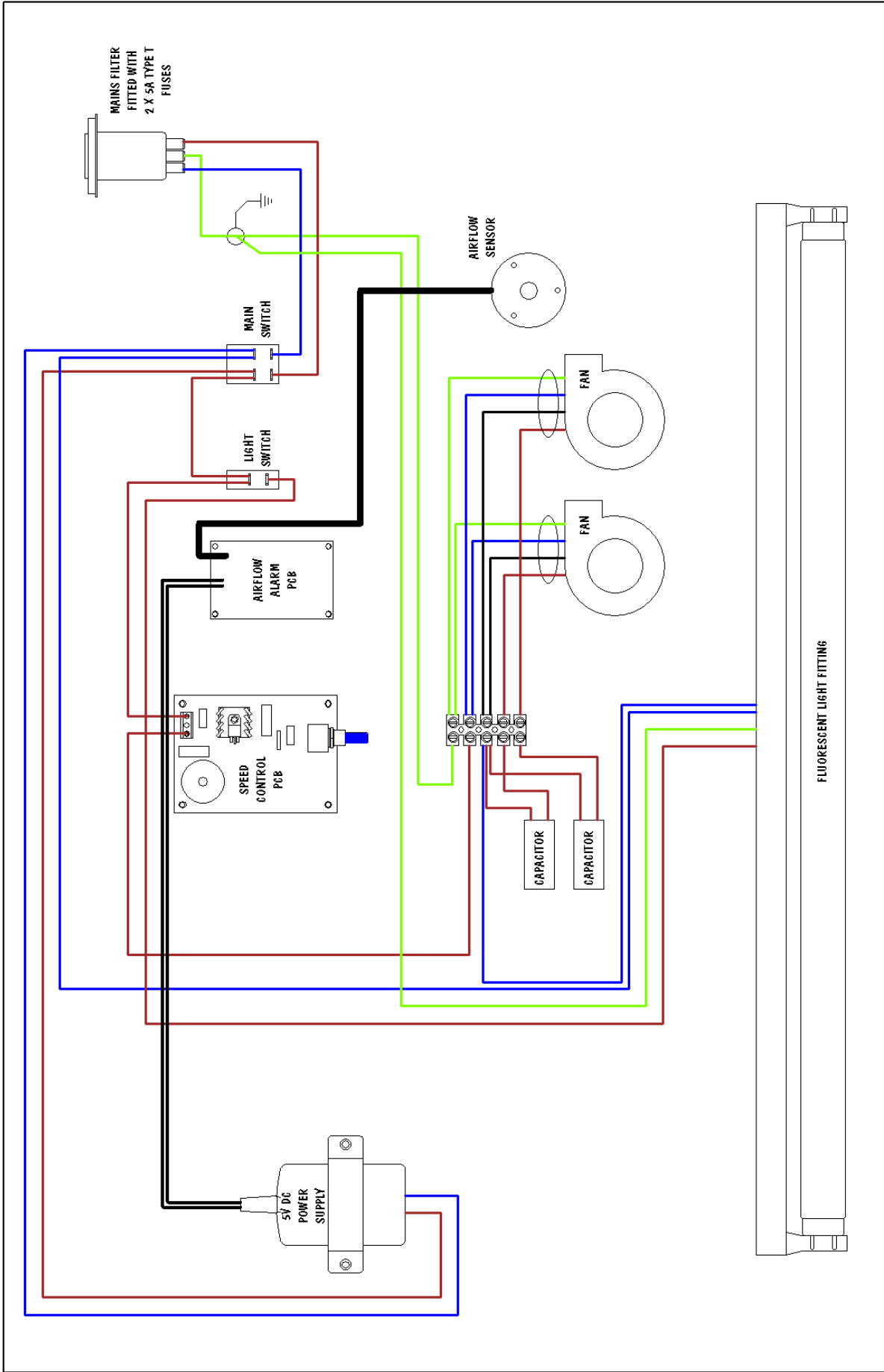

DRAWN PW DATE 12/01/11 PRIVATE AND CONFIDENTIAL	DESCRIPTION	ELECTRICAL DIAGRAM W1000
	DRAWING No	DFW / ELEC / 002 SH. 1 OF 1
<p><b>Monmouth Scientific</b>          A division of Monmouth Surgical Ltd.          Units 4 &amp; 5, Kilmore, East Quay, Bridgwater          Somerset, TA8 3JF, England          UK. Tel: +44 (0) 1272 455349          Fax: +44 (0) 1272 455351          email: <a href="mailto:engineering@monmouthscientific.co.uk">engineering@monmouthscientific.co.uk</a></p>		ISSUE A

## **CALIBRATION – LOW AIRFLOW ALARM – W700**

1. Before attempting to calibrate, ensure a clean main filter and pre-filter are fitted.
2. Switch on the W700 whilst simultaneously holding down the “Alarm mute” button, release once fan operates and the red/green LEDs should flash alternately.
3. Use a rotary vane anemometer (set to read in the range of 0.5m/sec) placed directly on the worksurface to take airflow measurements.
4. Partially block the exhaust outlet until an average airflow reading of 0.25m/sec is achieved at the worksurface.
5. Press the “Alarm mute” button and then unblock the exhaust outlet, the green LED should be constantly lit.
6. Turn cabinet off and then on again. Red LED should come and flash on for a few seconds until fan reaches normal operating speed and then the Green LED should light be confirming the airflow is at a satisfactory velocity.
7. The low airflow alarm can be tested by partially blocking the exhaust until airflow through the worksurface is reduced to below 0.25m/sec, the Red LED should light, and the alarm will beep, returning to green once the exhaust is unblocked and the airflow returns to normal.

## **CALIBRATION – LOW AIRFLOW ALARM – W1000**

**WARNING:** This procedure requires adjustment of live circuits and should only be carried out by a qualified person.

1. Before attempting to calibrate, ensure a clean main filter and pre-filter are fitted.
2. Remove the blanking plug on top of the unit to access the fan speed controller.
3. Switch on the W1000 whilst simultaneously holding down the “Alarm mute” button, release once fan operates and the red/green LEDs should flash alternately.
4. Use a rotary vane anemometer (set to read in the range of 0.5m/sec) placed directly on the worksurface to take airflow measurements.
5. Using a “Hot working” flat blade screwdriver, turn the fan speed adjustment potentiometer until an average airflow reading of 0.25m/sec is achieved at the worksurface.
6. Press the “Alarm mute” button. The green LED should now be constantly lit.
7. Adjust the speed controller again until an average airflow velocity of 0.4m/sec at the worksurface is achieved. (check airflow readings in at least 6 places across the worksurface)
8. Replace the adjustment blanking plug.
9. Turn cabinet off and then on again. Red LED should come and flash on for a few seconds until fan reaches normal operating speed and then the Green LED should light be confirming the airflow velocity is satisfactory.
10. The low airflow alarm can be tested by partially blocking the exhaust until airflow through the worksurface is reduced to below 0.25m/sec, the Red LED should light, and the alarm will beep, returning to green once the airflow returns to normal.



11.

## **SECTION 6**

### **SERVICING**

An annual service is recommended, and testing is mandatory under C.O.S.H.H regulations and will include the following points:

- Check / replace pre-filter
- Check and record downflow velocity readings
- Check airflow monitor and re-calibrate if necessary
- Inspect electrical components, lighting, cables etc.
- Issue test report and airflow certificate.

**For parts or service information please contact Benchvent on:  
+44 (0) 1423 790039**

# BenchVent

The Bench Ventilation Company

## **BENCHVENT**

Unit 1,  
Levens Hall Park,  
Harrogate,  
North Yorkshire,  
HG3 2BG.

**+44(0)1423 790039**

**[www.benchvent.com](http://www.benchvent.com)**  
**[info@benchvent.com](mailto:info@benchvent.com)**

